

Integración IV

Módulos de DWSIM (III)

Equipos con reacción química en DWSIM

2022

Profesor: Dr. Nicolás J. Scenna

JTP: Dr. Néstor H. Rodríguez

Aux. 1ra: Dr. Juan I. Manassaldi

Modelos de reactores presentes en DWSIM



Continuous Stirred Tank Reactor

CSTR model, supports Kinetic and HetCat reactions



Conversion Reactor

Supports reactions defined by amounts of reactant converted as a function of



Equilibrium Reactor

Supports equilibrium constant-defined reactions



Gibbs Reactor

Calculates chemical/atomic equilibrium for a Material Stream



Plug-Flow Reactor (PFR)

Plug-Flow Reactor model, supports Kinetic and HetCat reactions

Reacciones químicas soportadas por DWSIM

Las reacciones pueden ser de 4 tipos:

Equilibrio (*Equilibrium*): Se definen a partir de una constante de equilibrio (K). La fuente de información para la constante de equilibrio puede ser un cálculo directo de energía Gibbs, una expresión definida por el usuario o un valor constante. Pueden utilizarse en reactores de Equilibrium y Gibbs.

Conversión (*Conversion*): Se definen por la cantidad de un compuesto básico que se consume en la reacción. Esta cantidad puede ser un valor fijo o una función de la temperatura del sistema. Son soportadas por el reactor de Conversión.

Cinética (*Kinetic*): Se definen a partir de una expresión cinética. Son soportadas por los reactores PFR y CSTR.

Catalíticas heterogéneas (*Heterogeneous Catalytic*): Obedecen al mecanismo de Langmuir-Hinshelwood, donde los compuestos reaccionan sobre una superficie sólida de catalizador. En este modelo, las velocidades de reacción son una función de la cantidad de catalizador (es decir, mol/kg cat.s). Son soportadas por los reactores PFR y CSTR.

Modelos de reactores presentes en DWSIM

Para realizar una simulación de un reactor, se necesitan definir las reacciones químicas que tendrán lugar en el reactor. Esto se realiza a través del Administrador de Reacciones (Reactions Manager).

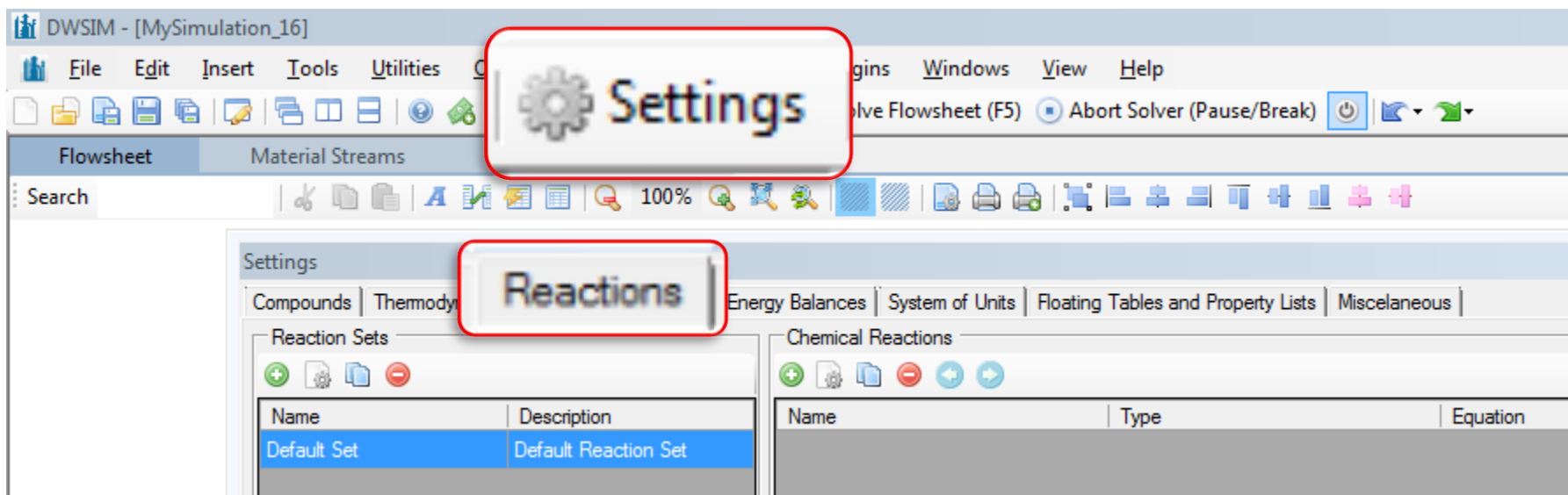

Administrador de Reacciones químicas (Chemical Reactions Manager).

The screenshot shows two panels. The 'Reaction Sets' panel on the left has a toolbar with a green plus icon, a gear icon, a blue folder icon, and a red minus icon. Below the toolbar is a table with two columns: 'Name' and 'Description'. The first row contains 'Default Set' and 'Default Reaction Set'. The 'Chemical Reactions' panel on the right has a toolbar with a green plus icon (circled in red), a gear icon, a blue folder icon, a red minus icon, and two blue arrow icons. Below the toolbar is a table with one column: 'Name'.

Name	Description
Default Set	Default Reaction Set

Name

The screenshot shows the 'Add New' menu in the 'Chemical Reactions' panel. The menu is open, showing a list of reaction types, each with a green plus icon in a circle. The items are: Conversion, Equilibrium, Kinetic, and Heterogeneous Catalytic. A red arrow points from the green plus icon in the toolbar above to the first item in the menu.

- Conversion
- Equilibrium
- Kinetic
- Heterogeneous Catalytic

Conversión

Equilibrio

Cinética

Catalíticas heterogéneas

Reacciones de Conversión

Add New Conversion Reaction

Identification

Name

Description

Nombre y descripción

Components/Stoichiometry

Name	Molar Weight	ΔH_f (kJ/kg)	Include	BC	Stoich. Coeff.
Nitrogen	28,0134	0	<input type="checkbox"/>	<input type="checkbox"/>	0
Hydrogen	2,01588	0	<input type="checkbox"/>	<input type="checkbox"/>	0
Ammonia	17,0305	-2695,04	<input type="checkbox"/>	<input type="checkbox"/>	0

Compuestos incluidos en la reacción

Stoichiometry

0

balance

Heat of Reaction (kJ/kmol_BC) (Δ)

0

Equatio

Conversion Reaction Parameters

Base Comp

Phase

Liquid

Conversion [%, f(T)] =

T in K

Use '.' as the decimal separator on the conversion expression.

Cancel

OK

Reacciones de Conversión

Add New Conversion Reaction

Identification

Name

Description

Coeficientes estequiométricos

Components/Stoichiometry

Name	Molar Weight	ΔH_f (kJ/kg)	Include	BC	Stoich. Coeff.
Nitrogen	28,0134	0	<input type="checkbox"/>	<input type="checkbox"/>	0
Hydrogen	2,01588	0	<input type="checkbox"/>	<input type="checkbox"/>	0
Ammonia				<input type="checkbox"/>	0

Componente base de la reacción

Stoichiometry

0

Balance

Heat of Reaction (kJ/kmol_BC) (25

0

Equatio

Verifica la estequiometria

Conversion Re:

Base Comp

Phase Liquid

Conversion [%, f(T)] =

T in K

Use '.' as the decimal separator on the conversion expression.

Cancel

OK

Reacciones de Conversión

Add New Conversion Reaction

Identification

Name

Description

Components/Stoichiometry

Name	Molar Weight	ΔH_f (kJ/kg)	Include	BC	Stoich. Coeff.
Nitrogen	28,0134	0	<input type="checkbox"/>	<input type="checkbox"/>	0
Hydrogen	2,01588	0	<input type="checkbox"/>	<input type="checkbox"/>	0
Ammonia	17,0305	-2695,04	<input type="checkbox"/>	<input type="checkbox"/>	~

Calor de reacción

Reacción

Balance

Heat of Reaction (kJ/kmol_BC) (25

0

Equatio

Fase de la reacción

Conversion Reaction Parameters

Base Comp

Phase Liquid

Conversion [%, $f(T)$ =

T in K

% de conversión en función de la temperatura

Cancel

OK

Ejemplos de Reacciones de Conversión



Add New Conversion Reaction ✕

Identification

Name

Description

Components/Stoichiometry

Name	Molar Weight	ΔH_f (kJ/kg)	Include	BC	Stoich. Coeff.
Nitrogen	28,0134	0	<input checked="" type="checkbox"/>	<input checked="" type="checkbox"/>	-1
Hydrogen	2,01588	0	<input checked="" type="checkbox"/>	<input type="checkbox"/>	-3
Ammonia	17,0305	-2695,04	<input checked="" type="checkbox"/>	<input type="checkbox"/>	2

Stoichiometry Heat of Reaction (kJ/kmol_BC) (25)

Equatio

Conversion Reaction Parameters

Base Comp Phase

Conversion [%, f(T)] = T in K

Use '.' as the decimal separator on the conversion expression.

Ejemplos de Reacciones de Conversión

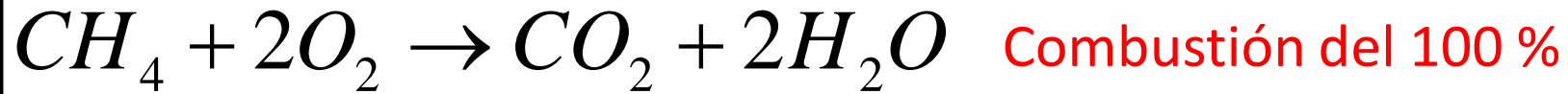

Add New Conversion Reaction

Identification

Name: Methane Combustion

Description:

Components/Stoichiometry

Name	Molar Weight	Include	BC	Stoich. Coeff.
Methane	16.043	<input checked="" type="checkbox"/>	<input checked="" type="checkbox"/>	-1
Carbon dioxide	44.0095	<input checked="" type="checkbox"/>	<input type="checkbox"/>	1
Water	18.015	<input checked="" type="checkbox"/>	<input type="checkbox"/>	2
Oxygen	31.999	<input checked="" type="checkbox"/>	<input type="checkbox"/>	-2
Nitrogen	28.014	<input type="checkbox"/>	<input type="checkbox"/>	0

Stoichiometry: OK Balance Heat of Reaction (kJ/kmol_BC) (25 °C): -802618

Equation: CH4 + 2O2 -> CO2 + 2H2O

Conversion Reaction Parameters

Base Comp: Methane Phase: Vapor

Conversion [%; f(T)] = 100 T in K

Use '.' as the decimal separator on the conversion expression.

Cancel OK

Include



El N₂ no interviene en la reacción.



Suele aparecer porque se utiliza aire para la combustión.

Reacciones de Equilibrio

Edit Equilibrium Reaction

Identification

Name: Butane Isomeration

Description:

Components/Stoichiometry

Name	Molar Weight	Include	BC	Stoich. Coeff.
N-butane	58.123	<input checked="" type="checkbox"/>	<input checked="" type="checkbox"/>	-1
Isobutane	58.123	<input checked="" type="checkbox"/>	<input type="checkbox"/>	1

Equilibrium Reaction Parameters

Basis: Fugacity Phase: Vapor Tmin (K): 0 Tmax (K): 0 Approach (%): 0

Equilibrium Constant (Keq)

Calculate from Gibbs Energy of Reaction ΔG_R (kJ/kmol_BC) (25°C): -4740

T-Function.: $\ln Keq [f(T)] =$ T in K

Constant Value: 0

Forma de calculo de la Keq

Use '.' as the decimal separator on math expressions.

Cancel OK

Ejemplos de Reacciones de Equilibrio

Edit Equilibrium Reaction

Identification

Name Ammonia Gibbs

Description $3H_2 + N_2 \rightleftharpoons 2NH_3$

Components/Stoichiometry

Name	Molar Weight	Include	BC	Stoich. Coeff.
Ammonia	17.031	<input checked="" type="checkbox"/>	<input type="checkbox"/>	2
Nitrogen	28.014	<input checked="" type="checkbox"/>	<input checked="" type="checkbox"/>	-1
Hydrogen	2.01588	<input checked="" type="checkbox"/>	<input type="checkbox"/>	-3

Stoichiometry Heat of Reaction (kJ/kmol_BC) (25°C) -91796

Equation N2 + 3H2 <-> 2NH3

Equilibrium Reaction Parameters

Basis Fugacity Phase Vapor Tmin (K) 0 Tmax (K) 0

Approach (%) 0

Equilibrium Constant (Keq)

Calculate from Gibbs Energy of Reaction DelG_R (kJ/kmol_BC) (25°C) -32800

T-Function.: ln Keq [f(T)] = T in K

Constant Value 0

Use '.' as the decimal separator on math expressions.

Ejemplos de Reacciones de Equilibrio

Edit Equilibrium Reaction

Identification

Name

Description

Components/Stoichiometry

Name	Molar Weight	Include	BC	Stoich. Coeff.
N-butane	58.123	<input checked="" type="checkbox"/>	<input checked="" type="checkbox"/>	-1
Isobutane	58.123	<input checked="" type="checkbox"/>	<input type="checkbox"/>	1

Stoichiometry Heat of Reaction (kJ/kmol_BC) (25°C)

Equation

Equilibrium Reaction Parameters

Basis Phase Tmin (K) Tmax (K)

Approach (%)

Equilibrium Constant (Keq)

Calculate from Gibbs Energy of Reaction

T-Function.: $\ln Keq [f(T)] =$ T in K

Constant Value

Use '.' as the decimal separator on math expressions.

Reacciones de Cinética

Add New Kinetic Reaction

Identification

Name

Descriptio

Orden de reacción (directo e inverso)

Components, Stoichiometry and Reaction Orders

Name	Molar Weight	ΔH_f (kJ/kg)	Include	BC	Stoich. Coeff.	DO	RO
Methyl acetate	74.0785	-5560.31	<input checked="" type="checkbox"/>	<input checked="" type="checkbox"/>	-1	1	0
Methanol	32.0419	-6271.17	<input checked="" type="checkbox"/>	<input type="checkbox"/>	1	0	1
1-butanol	74.1216	-3704.72	<input checked="" type="checkbox"/>	<input type="checkbox"/>	-1	1	0
N-butyl acetate	116.158	-4180.5	<input checked="" type="checkbox"/>	<input type="checkbox"/>	1	0	1

Stoichiometry Heat of Reaction (kJ/kmol_BC)

Equation

Kinetic Reaction Parameters

Parámetros de Arrhenius

concentrations

Tmin (K)

Tmax (K)

Direct and Reverse Reactions Velocity Constant (k and k')

Direct Reaction Arrhenius A E E in J/mol, T in K

User-Defined: f(T)

Reverse Reaction Arrhenius A' E' E in J/mol, T in K

User-Defined: f(T)

Amount Units Velocity Units

DO	RO
1	0
0	1
1	0
0	1

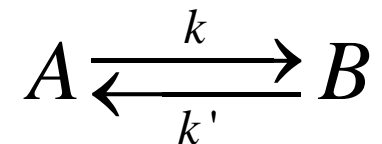

$$k = A e^{-\frac{E}{RT}}$$

$$k' = A' e^{-\frac{E'}{RT}}$$

Ejemplos de Reacciones de Cinética

Add New Kinetic Reaction

Identification

Name

Description

$$MeAc + BuOH \rightleftharpoons MeOH + BuAc$$

Components, Stoichiometry and Reaction Orders

Name	Molar Weight	ΔH_f (kJ/kg)	Include	BC	Stoich. Coeff.	DO	RO
Methyl acetate	74.0785	-5560.31	<input checked="" type="checkbox"/>	<input checked="" type="checkbox"/>	-1	1	0
Methanol	32.0419	-6271.17	<input checked="" type="checkbox"/>	<input type="checkbox"/>	1	0	1
1-butanol	74.1216	-3704.72	<input checked="" type="checkbox"/>	<input type="checkbox"/>	-1	1	0
N-butyl acetate	116.158	-4180.5	<input checked="" type="checkbox"/>	<input type="checkbox"/>	1	0	1

Stoichiometry Heat of Reaction (kJ/kmol_BC)

Equation

Kinetic Reaction Parameters

Base Component Basis Tmin (K)

Phase Tmax (K)

Direct and Reverse Reactions Velocity Constant (k and k')

Direct Reaction Arrhenius A E E in J/mol, T in K

User-Defined: f(T)

Reverse Reaction Arrhenius A' E' E in J/mol, T in K

User-Defined: f(T)

Amount Units Velocity Units

Ejemplos de Reacciones de Cinética

Edit Kinetic Reaction

Identification

Name: Styrene

Description: $C_6H_5 - C_2H_5 \Leftrightarrow C_6H_5 - C_2H = CH_2 + H_2$

Components, Stoichiometry and Reaction Orders

Name	Molar Weight	ΔH_f (kJ/kg)	Include	BC	Stoich. Coeff.	DO	RO
Ethylbenzene	106.167	281.82015	<input checked="" type="checkbox"/>	<input checked="" type="checkbox"/>	-1	1	0
Styrene	104.149	1415.28	<input checked="" type="checkbox"/>	<input type="checkbox"/>	1	0	0
Hydrogen	2.01588	0	<input checked="" type="checkbox"/>	<input type="checkbox"/>	1	0	0

Stoichiometry: OK Balance Heat of Reaction (kJ/kmol_BC): 117480

Equation: (C6H5)CH2CH3 <-> (C6H5)CHCH2 + H2

Kinetic Reaction Parameters

Base Component: Ethylbenzene

Basis: Partial Pressures Tmin (K): 0

Phase: Vapor Tmax (K): 3500

Direct and Reverse Reactions Velocity Constant (k and k')

Direct Reaction: Arrhenius A: 4240 E: 90826 E in J/mol, T in K

User-Defined: f(T)

Reverse Reaction: Arrhenius A': 0 E': 0 E in J/mol, T in K

User-Defined: f(T)

Amount Units: kPa Velocity Units: mol/[L.s]

Cancel OK

Reacciones Heterogéneas Catalíticas

Heterogeneous Catalytic Reaction

Identification

Name: MeOH Dehydration

Description:

Components and Stoichiometry

Name	Molar Weight	ΔH_f (kJ/kg)	Include	BC	SC
Methanol	32.042	-6271.1441	<input checked="" type="checkbox"/>	<input checked="" type="checkbox"/>	-2
Water	18.015	-13422.925	<input checked="" type="checkbox"/>	<input type="checkbox"/>	1
Dimethyl ether	46.069	-3996.1796	<input checked="" type="checkbox"/>	<input type="checkbox"/>	1

Stoichiometry: OK Balance Heat of Reaction (kJ/kmol_BC): -12017

Equation: $2\text{CH}_3\text{OH} \leftrightarrow \text{HOH} + \text{CH}_3\text{OCH}_3$ Base Component: Methanol

Heterogeneous Kinetic Reaction Parameters

Basis: Molar Fractions Phase: Vapor Tmin (K): 0 Tmax (K): 3500

Reaction Rate (Base Component) = Numerator / Denominator

Numerator: $12000000000 \cdot \exp(-8 - 9680/T) \cdot (R1 - P2 \cdot P1/R1 / \exp(-2.8086 + 3061/T))$

Denominator: 1

Expression Variables: Temperature (T) in K, reactant amounts (R1, R2, ..., Rn) and product amounts (P1, P2, ..., Pn) in the selected amount unit, reaction rate (r) in the selected velocity unit.

Amount Unit: Velocity Unit: mol/[kg.s]

Use '.' as the decimal separator on math expressions.

Cancel OK

Ley funcional de la velocidad de reacción

Las variables son:

T

R_1, R_2, \dots, R_n

P_1, P_2, \dots, P_n

Reacciones Heterogéneas Catalíticas

Heterogeneous Catalytic Reaction

Identification

Name: MeOH Dehydration

Description:

$$2CH_3OH \rightleftharpoons H_2O + CH_3OCH_3$$

Components and Stoichiometry

Name	Molar Weight	ΔH_f (kJ/kg)	Include	BC	SC
Methanol	32.042	-6271.1441	<input checked="" type="checkbox"/>	<input checked="" type="checkbox"/>	-2
Water	18.015	-13422.925	<input checked="" type="checkbox"/>	<input type="checkbox"/>	1
Dimethyl ether	46.069	-3996.1796	<input checked="" type="checkbox"/>	<input type="checkbox"/>	1

Stoichiometry: Heat of Reaction (kJ/kmol_BC): -12017

Equation: Base Component:

Heterogeneous Kinetic Reaction Parameters

Basis: Phase: Tmin (K): Tmax (K):

Reaction Rate (Base Component) = Numerator / Denominator

Numerator:

Denominator:

Expression Variables: Temperature (T) in K, reactant amounts (R1, R2, ..., Rn) and product amounts (P1, P2, ..., Pn) in the selected amount unit, reaction rate (r) in the selected velocity unit.

Amount Unit: Velocity Unit:

Use '.' as the decimal separator on math expressions.

Reacciones Heterogéneas Catalíticas

Heterogeneous Catalytic Reaction

Identification

Name: Water Gas Shift

Description:

$$H_2O + CO \rightleftharpoons H_2 + CO_2$$

Components and Stoichiometry

Name	Molar Weight	Include	BC	SC
Methane	16.043	<input type="checkbox"/>	<input type="checkbox"/>	0
Hydrogen	2.01588	<input checked="" type="checkbox"/>	<input type="checkbox"/>	1
Water	18.015	<input checked="" type="checkbox"/>	<input type="checkbox"/>	-1
Carbon dioxide	44.0095	<input checked="" type="checkbox"/>	<input type="checkbox"/>	1
Carbon monoxide	28.01	<input checked="" type="checkbox"/>	<input checked="" type="checkbox"/>	-1

Stoichiometry: OK Balance Heat of Reaction (kJ/kmol_BC): -41166.0

Equation: HOH + CO <-> H2 + OCO Base Component: Carbon monoxide

Heterogeneous Kinetic Reaction Parameters

Basis: Partial Pressures Phase: Vapor Tmin (K): 0 Tmax (K): 2000

Reaction Rate (Base Component) = Numerator / Denominator

Numerator: $1.96E+6 \cdot \exp(-67130/8.314/T) / P1 \cdot (R1 \cdot R2 - P1 \cdot P2 / (\exp(-3.798 + 4160/T)))$

Denominator: $(1 + 1.77E+5 \cdot \exp(-88680/8.314/T) \cdot R1 / P1 + 6.12E-9 \cdot \exp(82900/8.314/T) \cdot P1 + 8.23E-5 \cdot \exp(70650/8.314/T) \cdot P1 \cdot P2)$

Expression Variables: Temperature (T) in K, reactant amounts (R1, R2, ..., Rn) and product amounts (P1, P2, ..., Pn) in the selected amount unit, reaction rate (r) in the selected velocity unit.

Amount Unit: atm Velocity Unit: kmol/[kg.h]

Use '.' as the decimal separator on math expressions.

Cancel OK

Reacciones Heterogéneas Catalíticas

Heterogeneous Catalytic Reaction

Identification

Name: Steam Reforming

Description:

$$CH_4 + H_2O \rightleftharpoons 3H_2 + CO$$

Components and Stoichiometry

Name	Molar Weight	Include	BC	SC
Methane	16.043	<input checked="" type="checkbox"/>	<input checked="" type="checkbox"/>	-1
Hydrogen	2.01588	<input checked="" type="checkbox"/>	<input type="checkbox"/>	3
Water	18.015	<input checked="" type="checkbox"/>	<input type="checkbox"/>	-1
Carbon dioxide	44.0095	<input type="checkbox"/>	<input type="checkbox"/>	0
Carbon monoxide	28.01	<input checked="" type="checkbox"/>	<input type="checkbox"/>	1

Stoichiometry: Heat of Reaction (kJ/kmol_BC): 205804.0

Equation: CH4 + HOH <-> 3H2 + CO Base Component: Methane

Heterogeneous Kinetic Reaction Parameters

Basis: Phase: Tmin (K): Tmax (K):

Reaction Rate (Base Component) = Numerator / Denominator

Numerator: $4.22E+15 \cdot \exp(-240100/8.314/T) / P1^{2.5} (R1 \cdot R2 \cdot P1^3 \cdot P2 / (\exp(30.42 - 27106/T)))$

Denominator: $(1 + 8.23E-5 \cdot \exp(70650/8.314/T) \cdot P2 + 6.65E-4 \cdot \exp(38280/8.314/T) \cdot R1 + 1.77E+5 \cdot \exp(-88680/8.314/T))$

Expression Variables: Temperature (T) in K, reactant amounts (R1, R2, ..., Rn) and product amounts (P1, P2, ..., Pn) in the selected amount unit, reaction rate (r) in the selected velocity unit.

Amount Unit: Velocity Unit:

Use '.' as the decimal separator on math expressions.

Ejemplo: Combustión de gas natural

Se desea conocer la temperatura de llama que se alcanza al quemar 1 kg/s de gas natural (suponemos metano puro) con una relación másica de 1:40 fuel-aire. Se considera que el gas y el aire ingresan a 298.15 y 1 atm.

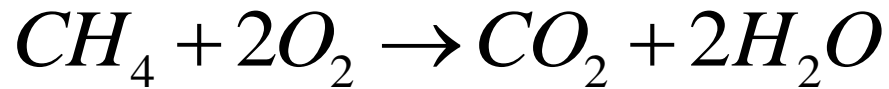

The screenshot shows the configuration of a simulation. On the left, a table lists the species added to the simulation:

Added	Name
<input checked="" type="checkbox"/>	Methane
<input checked="" type="checkbox"/>	Oxygen
<input checked="" type="checkbox"/>	Nitrogen
<input checked="" type="checkbox"/>	Water
<input checked="" type="checkbox"/>	Carbon dioxide

On the right, the 'Added Property Packages' window shows 'Raoult's Law (1)' selected. A red arrow points from the 'Methane' row in the table to this entry. Below it, the 'Chemical Reactions' window shows 'Conversion' selected, with a red box around it. A red arrow points from the 'Raoult's Law (1)' entry to the 'Conversion' option.

Reacción de combustión del metano

Edit Conversion Reaction ✕

Identification

Name

Description

Components/Stoichiometry

Name	Molar Weight	Include	BC	Stoich. Coeff.
Methane	16.043	<input checked="" type="checkbox"/>	<input checked="" type="checkbox"/>	-1
Oxygen	31.999	<input checked="" type="checkbox"/>	<input type="checkbox"/>	-2
Nitrogen	28.014	<input type="checkbox"/>	<input type="checkbox"/>	0
Water	18.015	<input checked="" type="checkbox"/>	<input type="checkbox"/>	2
Carbon dioxide	44.0095	<input checked="" type="checkbox"/>	<input type="checkbox"/>	1

Stoichiometry Heat of Reaction (kJ/kmol_BC) (25 °C)

Equation

Conversion Reaction Parameters

Base Comp Phase

Conversion [%, f(T)] = T in K

Use '.' as the decimal separator on the conversion expression.

Corriente de combustible

Input Data | Results | Annotations | Floating Tables

Stream Conditions | Compound Amounts

Flash Spec

Temperature

Pressure

Mass Flow

Molar Flow

Volumetric Flow

Specific Enthalpy

Specific Entropy

Vapor Phase Mole Fraction

Stream Conditions | Compound Amounts

Basis

Solvent

Compound	Amount
Methane	1
Oxygen	0
Nitrogen	0
Water	0
Carbon dioxide	0

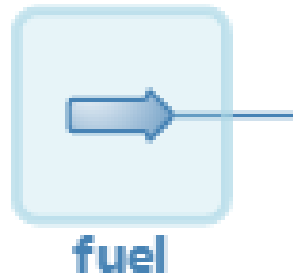

Corriente de aire

Input Data | Results | Annotations | Floating Tables

Stream Conditions | Compound Amounts

Flash Spec

Temperature K

Pressure Pa

Mass Flow kg/s

Molar Flow mol/s

Volumetric Flow m³/s

Specific Enthalpy kJ/kg

Specific Entropy kJ/[kg.K]

Vapor Phase Mole Fraction

Stream Conditions | Compound Amounts

Basis

Solvent

Compound	Amount
Methane	0
Oxygen	0.21
Nitrogen	0.79
Water	0
Carbon dioxide	0

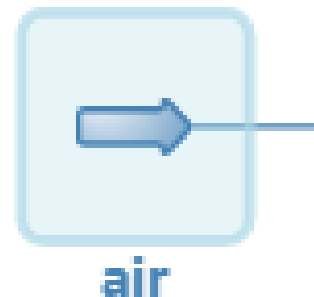

Mezcla para ingresar al reactor

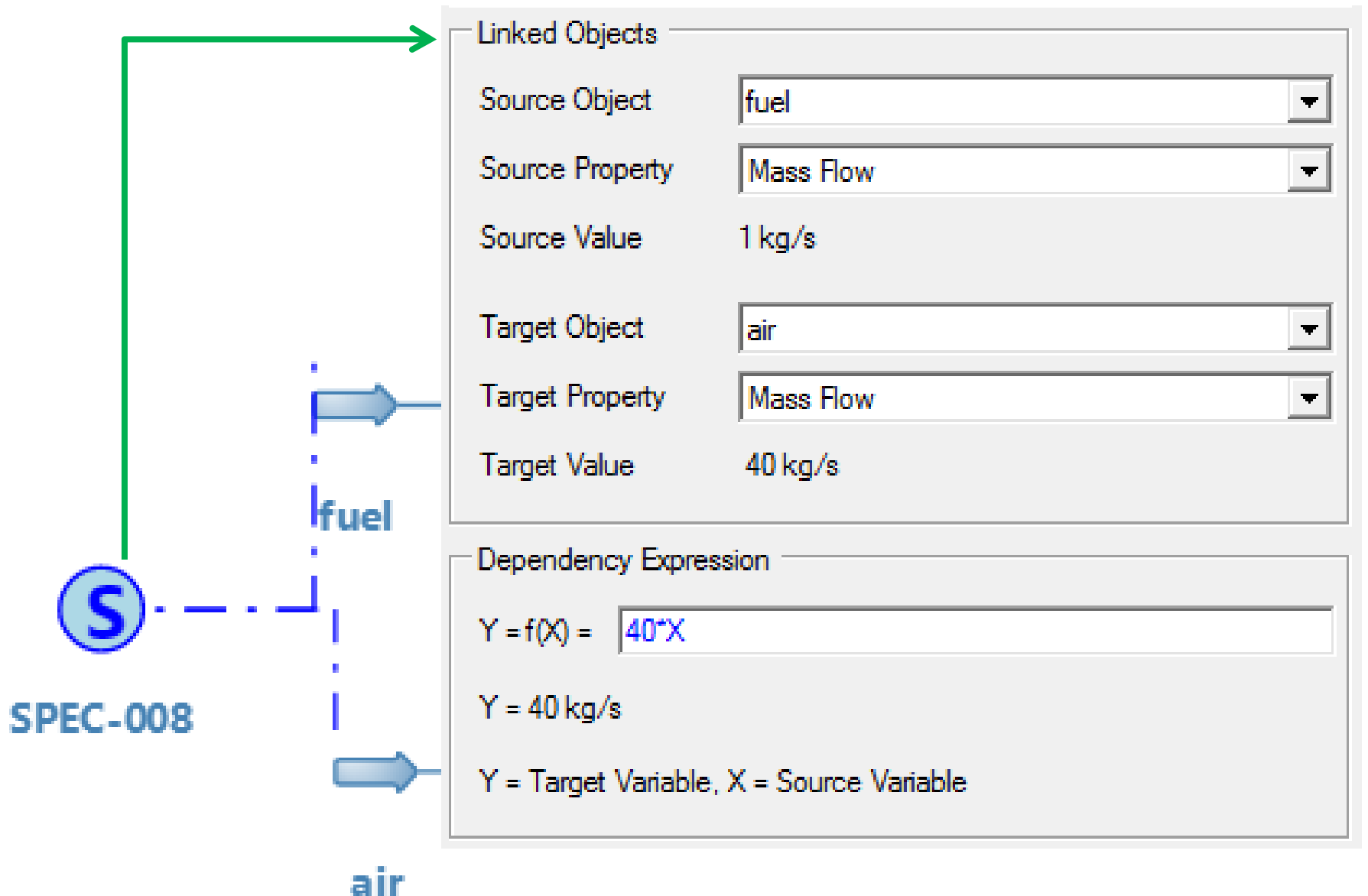

Reactor de conversión

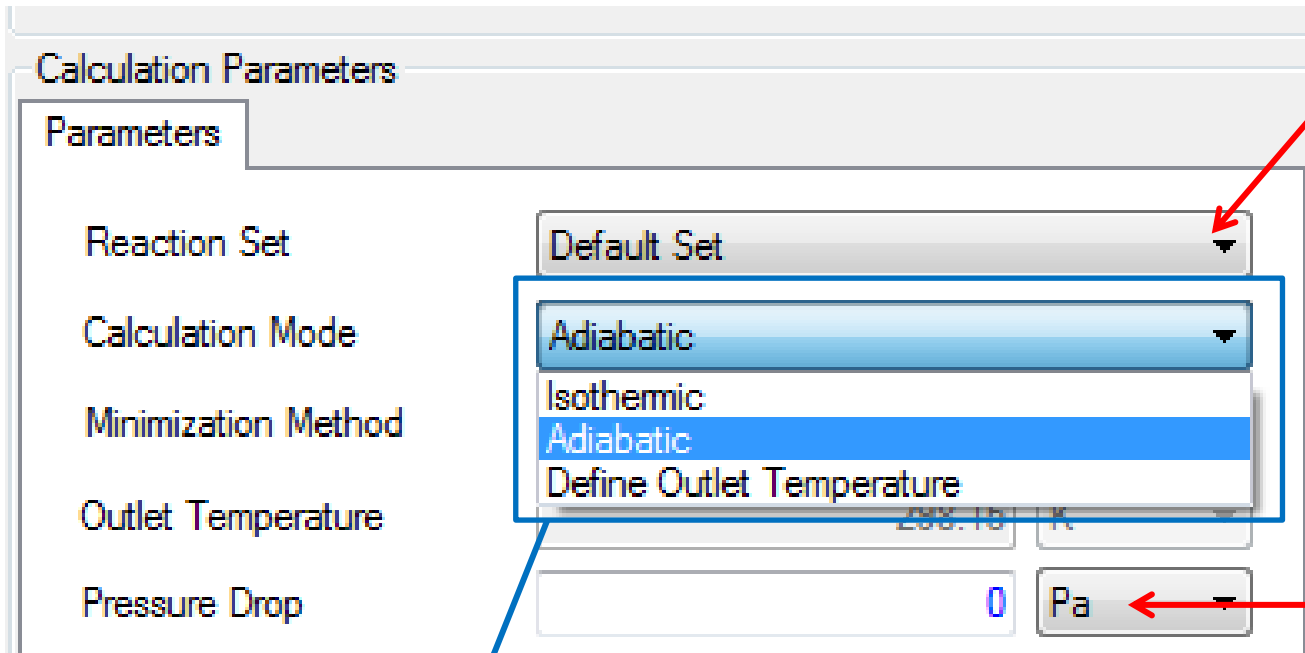

Paquete de reacciones que intervienen en el reactor

Caída de presión

Métodos de calculo disponibles:

- Isotérmico
- Adiabático
- Con temperatura de salida definida

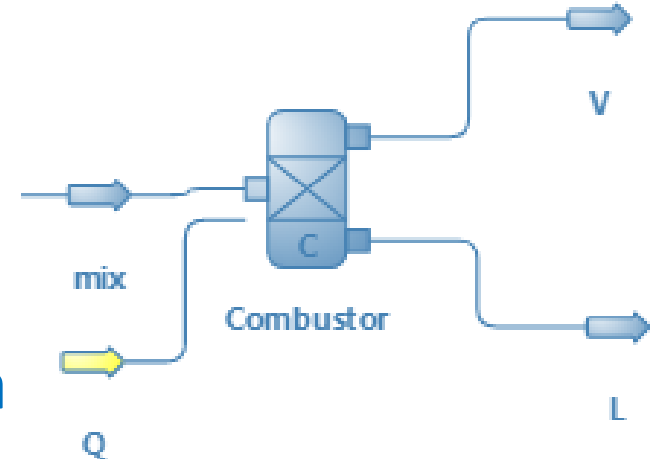

Reactor de conversión

Calculation Parameters

Parameters

Reaction Set: Default Set

Calculation Mode: Adiabatic

Minimization Method: []

Outlet Temperature: 298.15 K

Pressure Drop: 0 Pa

Temperature: 1338.1484 K

Pressure: 101325 Pa

Mass Flow: 41 kg/s

Molar Flow: 1448.7767 mol/s

Compound	Amount
Methane	0
Oxygen	0.11491627
Nitrogen	0.75601079
Water	0.086048626
Carbon dioxide	0.043024313

Results

General Reactions Conversions

Property	Value	Units
Delta-T	1039.9984	K
Heat Load	0	kW

General Reactions Conversions

Reaction	Property	Value	Units
Metano Comb	Conversion	100	%

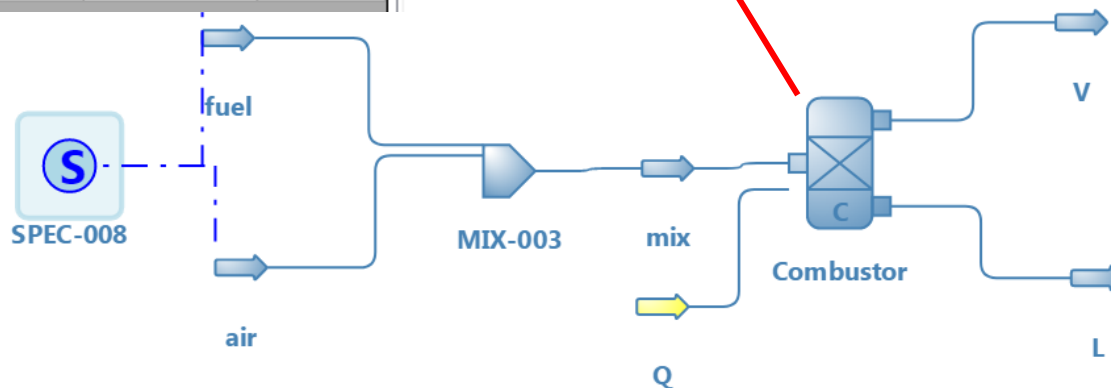

Ejemplo: Simulación de una turbina de Gas

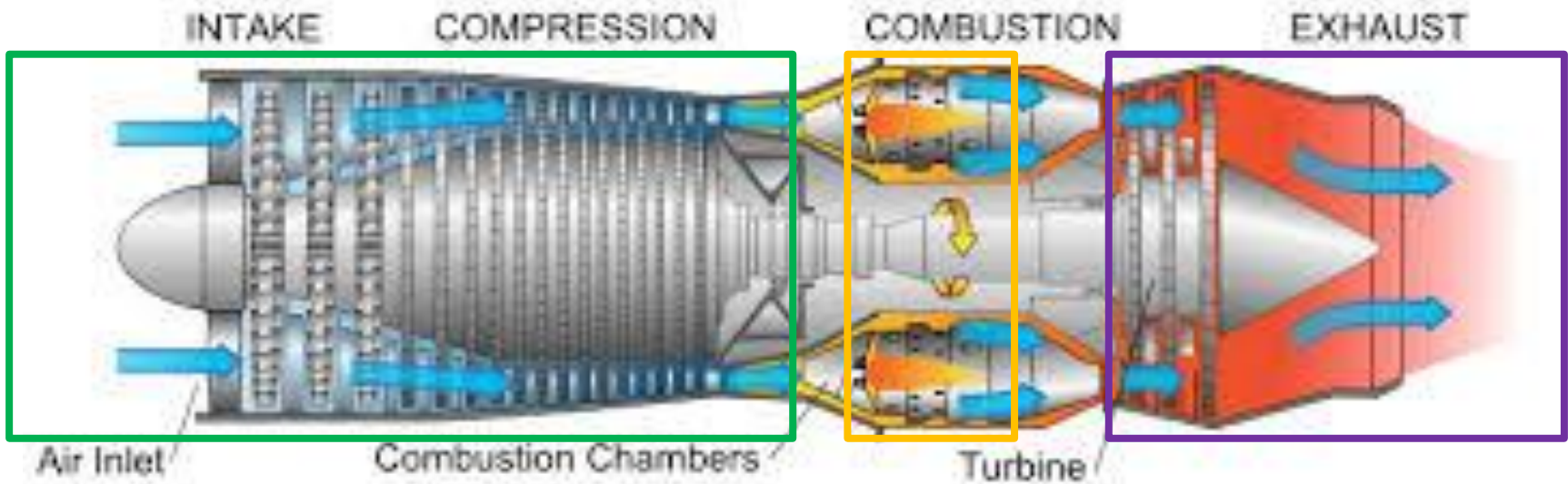
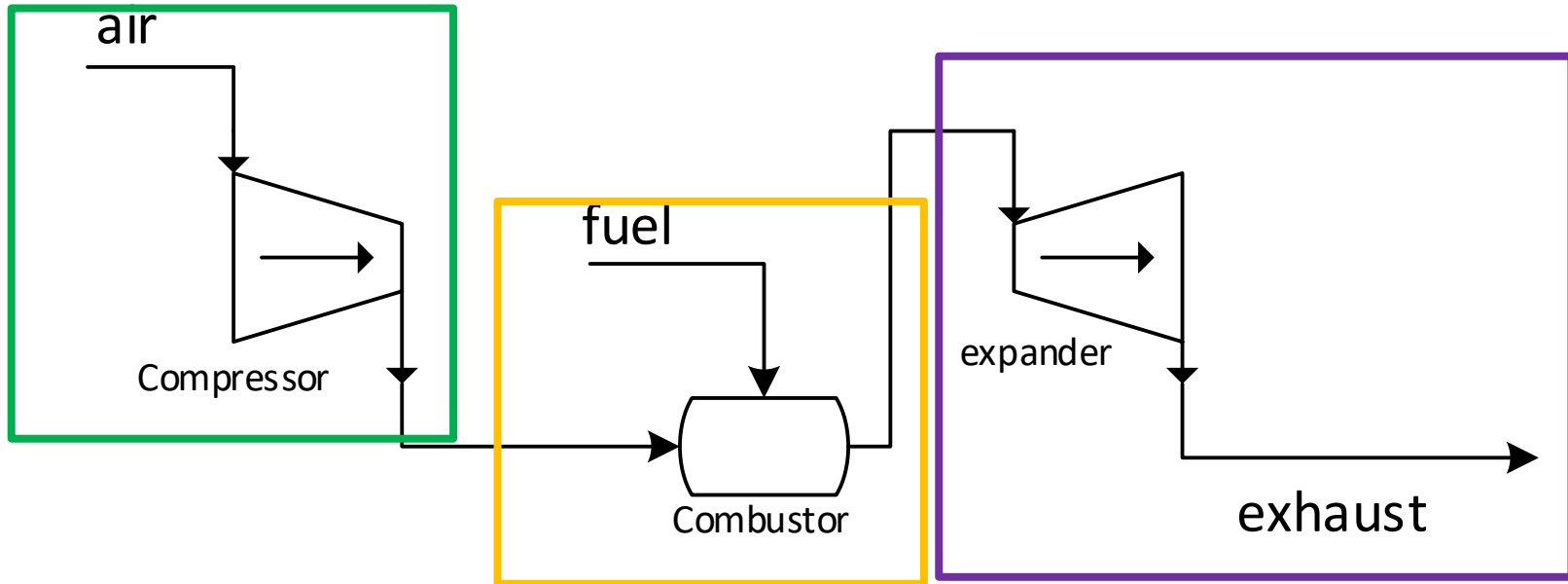

Ejemplo: Simulación de una turbina de Gas

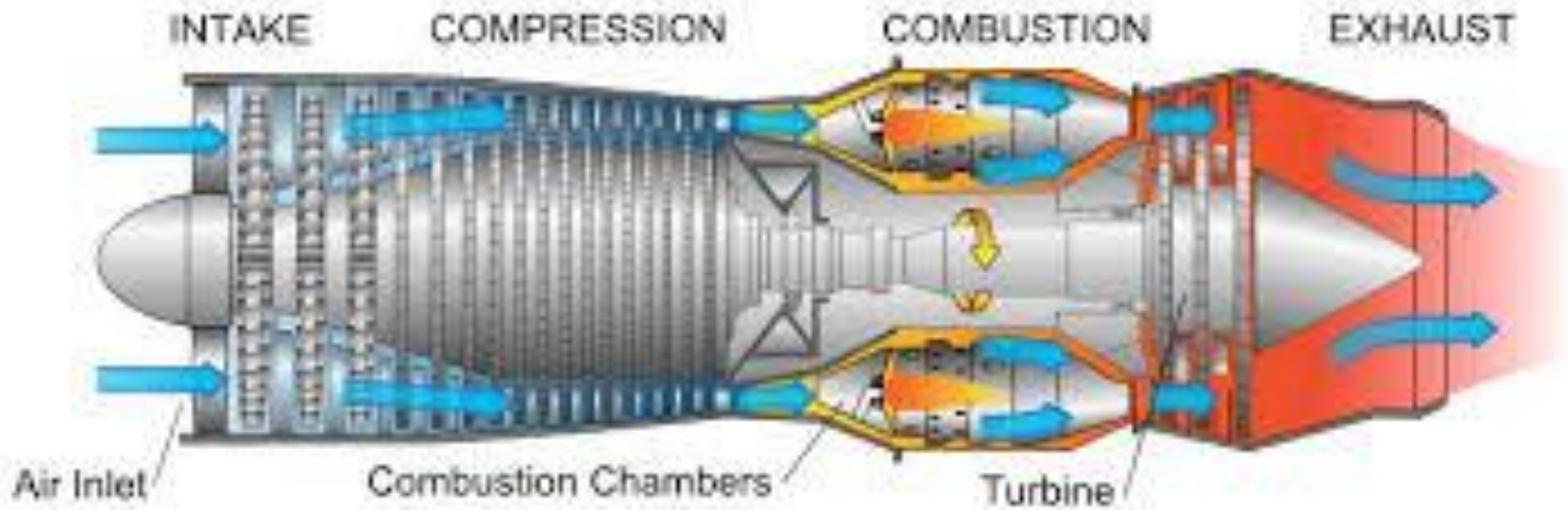
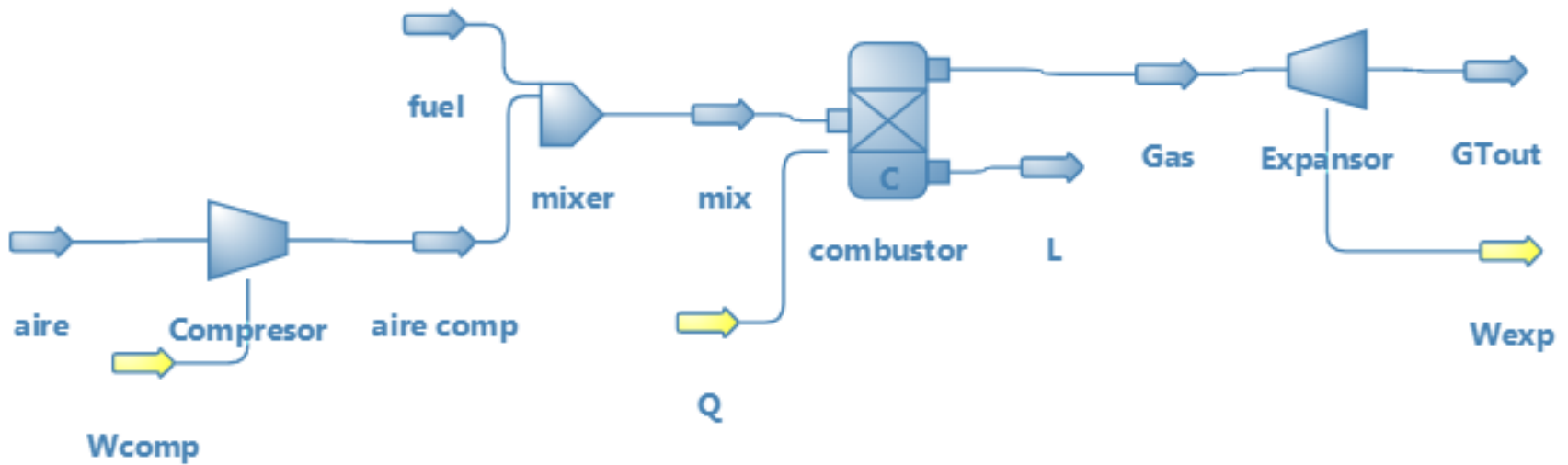

Ejemplo: Simulación de una turbina de Gas

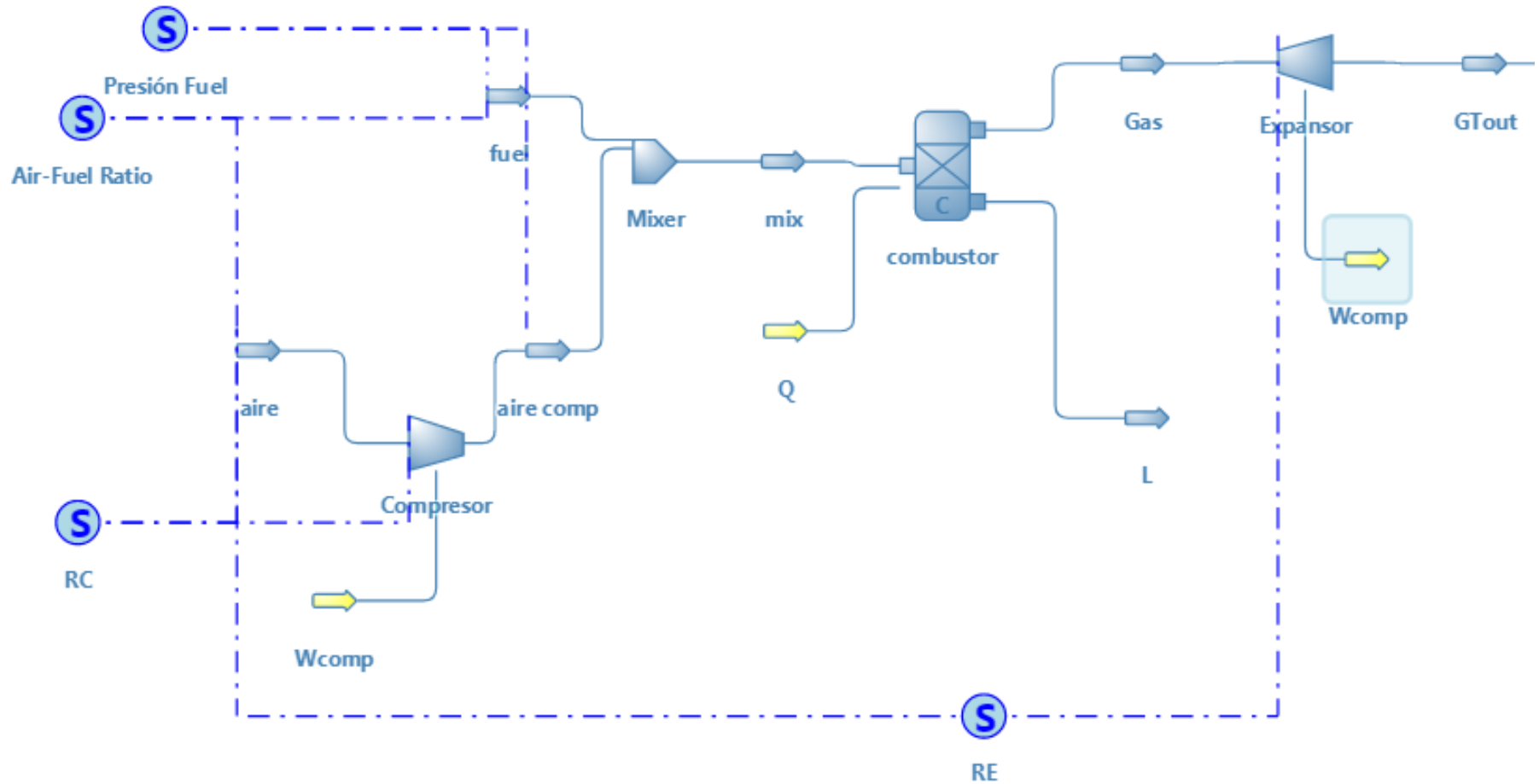

Ejemplo: Reactor de equilibrio

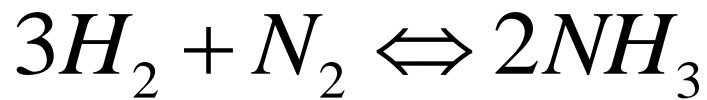

Alimentación estequiométrica

Added	Name
<input checked="" type="checkbox"/>	Ammonia
<input checked="" type="checkbox"/>	Nitrogen
<input checked="" type="checkbox"/>	Hydrogen

Added Property Packages

Name (click to edit)	Type
Peng-Robinson (PR) (1)	Peng-Robinson (PR)

Chemical Reactions

<input checked="" type="checkbox"/>	Conversion
<input checked="" type="checkbox"/>	Equilibrium
<input checked="" type="checkbox"/>	Kinetic
<input checked="" type="checkbox"/>	Heterogeneous Catalytic

Reacción de equilibrio

Edit Equilibrium Reaction

Identification

Name: Ammonia Gibbs

Description:

Components/Stoichiometry

Name	Molar Weight	Include	BC	Stoich. Coeff.
Ammonia	17.031	<input checked="" type="checkbox"/>	<input type="checkbox"/>	2
Nitrogen	28.014	<input checked="" type="checkbox"/>	<input checked="" type="checkbox"/>	-1
Hydrogen	2.01588	<input checked="" type="checkbox"/>	<input type="checkbox"/>	-3

Stoichiometry: OK Balance Heat of Reaction (kJ/kmol_BC) (25°C): -91796

Equation: $N_2 + 3H_2 \leftrightarrow 2NH_3$

Equilibrium Reaction Parameters

Basis: Fugacity Phase: Vapor Tmin (K): 0 Tmax (K): 0

Approach (%): 0

Equilibrium Constant (Keq)

Calculate from Gibbs Energy of Reaction ΔG_R (kJ/kmol_BC) (25°C): -32800

T-Function.: $\ln Keq [f(T)] =$ T in K

Constant Value: 0

Use '.' as the decimal separator on math expressions.

Cancel OK

Reactor de equilibrio 450 °C 100 atm

Stream Conditions | Compound Amounts

Flash Spec: Temperature and Pressure (TP)

Temperature: 723.15 K

Pressure: 10132500 Pa

Mass Flow: 0.0851541 kg/s

Molar Flow: 10 mol/s

Volumetric Flow: 0.0060835443 m³/s

Specific Enthalpy: 1480.9576 kJ/kg

Specific Entropy: -0.45617289 kJ/[kg.K]

Vapor Phase Mole Fraction: 1

Stream Conditions | Compound Amounts

Basis: Mole Fractions

Solvent:

Compound	Amount
Ammonia	0
Nitrogen	0.25
Hydrogen	0.75

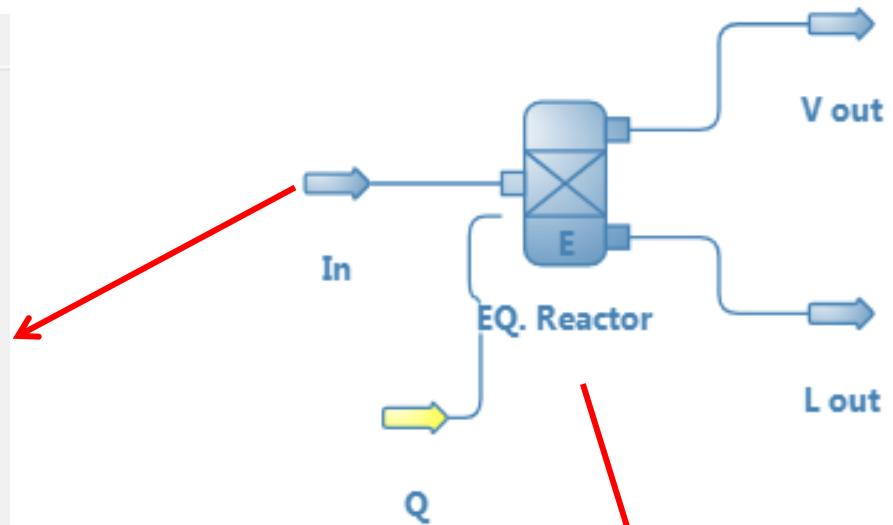

Calculation Parameters

Parameters | Convergence

Reaction Set: Default Set

Calculation Mode: Isothermic

Minimization Method:

Outlet Temperature: 298.15 K

Pressure Drop: 0 Pa

Results

General | Reactions | Conversions

Compound	Conversion (%)
Nitrogen	28.759722
Hydrogen	28.759722

Reactor de Gibbs

Calculation Parameters

Parameters Compounds Elements Initial Estimates Misc

Reaction Set Default Set

Calculation Mode Isothermic

Minimization Method Direct Gibbs Energy Minimization

Outlet Temperature 298.15 K

Pressure Drop 0 Pa

Calculation Parameters

Parameters Compounds Elements Initial Estimates Misc

- Ammonia
- Nitrogen
- Hydrogen

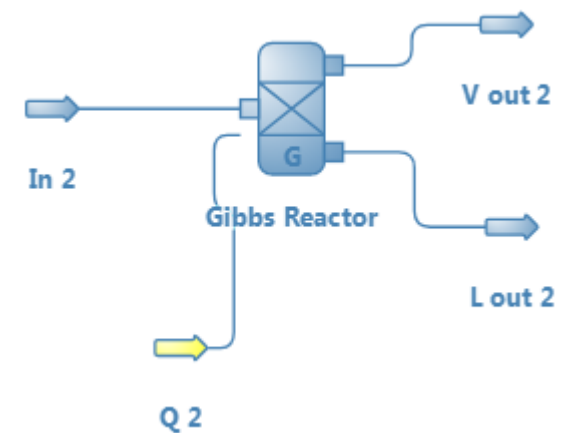

Reactor de Gibbs

Calculation Parameters

Parameters

Compounds

Elements

Initial Estimates

Misc

Configuration

Add Element

Remove Selected Element

Save Changes

Create from Selected Components

Matrix

	Element	Ammonia	Nitrogen	Hydrogen
	N	1	2	0
	H	3	0	2

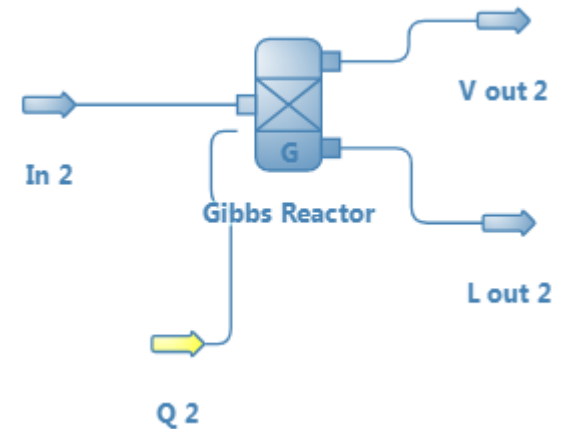

Reactor de Gibbs

Calculation Parameters

Parameters | Compounds | Elements | **Initial Estimates** | Misc

Configuration

Copy from inlet stream Copy from outlet liquid stream

Copy from outlet vapor stream

Initial Estimates

Compound	Estimates for Outlet Mole Flows (mol/s)
Ammonia	0
Nitrogen	0
Hydrogen	0

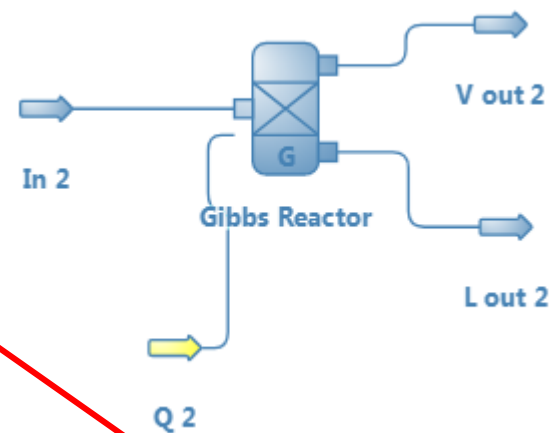

Calculation Parameters

Parameters | Compounds | Elements | Initial Estimates | **Misc**

Use Damping Factor (Newton's Method)

Lower Limit 0.001

Upper Limit 2

Max. Internal Loop Iterations 20000

Max. External Loop Iterations 50

Internal Loop Tolerance 1E-06

External Loop Tolerance 0.001

Ejemplo: Reactor CSTR y PFR

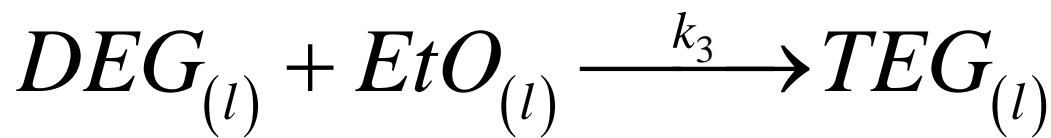
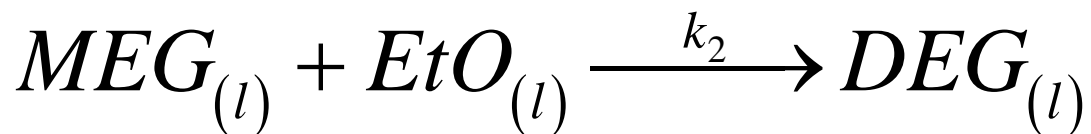
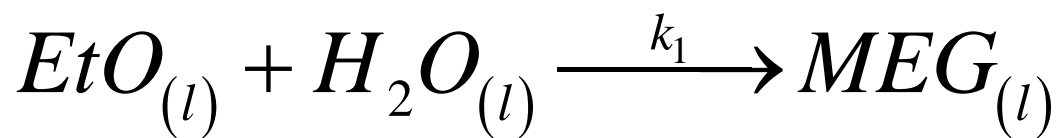

Added	Name
<input checked="" type="checkbox"/>	Ethylene oxide
<input checked="" type="checkbox"/>	Water
<input checked="" type="checkbox"/>	Ethylene glycol
<input checked="" type="checkbox"/>	Diethylene glycol
<input checked="" type="checkbox"/>	Triethylene glycol

$$k_1/[L/(mol \cdot min)] = \exp(13.62 - 8220/T)$$

$$k_2/[L/(mol \cdot min)] = \exp(15.57 - 8700/T)$$

$$k_3/[L/(mol \cdot min)] = \exp(16.06 - 8900/T)$$



A. Carrero, N. Quirante, J. Javaloyes

October 2016

Feed in

x_{water} : 0.7

x_{EtO} : 0.3

P: 20 atm

T: 100 °C

m: 100 mol/s

Ejemplo: Reactor CSTR y PFR



Components, Stoichiometry and Reaction Orders

Name	Molar Weight	ΔH_f (kJ/kg)	Include	BC	Stoich. Coeff.	DO	RO
Ethylene oxide	44.0526	-1194.7081	<input checked="" type="checkbox"/>	<input checked="" type="checkbox"/>			
Water	18.015	-13422.925	<input checked="" type="checkbox"/>	<input type="checkbox"/>			
Ethylene glycol	62.0678	-6318.8964	<input checked="" type="checkbox"/>	<input type="checkbox"/>			
Diethylene glycol	106.12	-5148.8881	<input type="checkbox"/>	<input type="checkbox"/>			
Triethylene glycol	150.173	-4828.4312	<input type="checkbox"/>	<input type="checkbox"/>			

Kinetic Reaction Parameters

Base Component: Basis: T_{min} (K):
 Phase: T_{max} (K):

Direct and Reverse Reactions Velocity Constant (k and k')

Direct Reaction: Arrhenius A: E: E in J/mol, T in K
 User-Defined: f(T)

Reverse Reaction: Arrhenius A': E': E in J/mol, T in K
 User-Defined: f(T)

Amount Units: Velocity Units:

Ejemplo: Reactor CSTR y PFR



$$(-r_{EtO}) = k_1 C_{EtO} C_{H_2O} \quad k_1 = A_1 e^{-\frac{E_1}{RT}}$$

Kinetic Reaction Parameters

Base Component	Ethylene oxide	Basis	Molar Concentrations	Tmin (K)	0
		Phase	Liquid	Tmax (K)	3500

Direct and Reverse Reactions Velocity Constant (k and k')

Direct Reaction	<input checked="" type="radio"/> Arrhenius	A		E		E in J/mol, T in K
	<input type="radio"/> User-Defined: f(T)					
Reverse Reaction	<input checked="" type="radio"/> Arrhenius	A'	0	E'	0	E in J/mol, T in K
	<input type="radio"/> User-Defined: f(T)					

Amount Units Velocity Units

Define las unidades de la expresión cinética

Ejemplo: Reactor CSTR y PFR



$$(-r_{EtO}) = k_1 C_{EtO} C_{H_2O} \quad k_1 \left[\begin{matrix} \text{?} \\ \text{?} \end{matrix} \right] \quad C_{EtO}; C_{H_2O} \left[\frac{mol}{m^3} \right]$$

$$k_1 = A_1 e^{-\frac{E_1}{RT}} \quad (-r_{EtO}) \left[\frac{mol}{m^3 s} \right]$$

Kinetic Reaction Parameters

Base Component:

Basis:

Phase:

Tmin (K):

Tmax (K):

Direct and Reverse Reactions Velocity Constant (k and k')

Direct Reaction: Arrhenius A E E in J/mol, T in K

User-Defined: f(T)

Reverse Reaction: Arrhenius A' E' E in J/mol, T in K

User-Defined: f(T)

Amount Units:

Velocity Units:

Ejemplo: Reactor CSTR y PFR



$$k_1 = A_1 e^{-\frac{E_1}{RT}}$$

$$A_1 \left[\frac{m^3}{mol.s} \right] \quad E_1 \left[\frac{J}{mol} \right] \quad T [K]$$

$$k_1 \left[\frac{m^3}{mol.s} \right]$$

Kinetic Reaction Parameters

Base Component:

Basis:

Phase:

Tmin (K):

Tmax (K):

Direct and Reverse Reactions Velocity Constant (k and k')

Direct Reaction: Arrhenius A E E in J/mol, T in K

User-Defined: f(T)

Reverse Reaction: Arrhenius A' E' E in J/mol, T in K

User-Defined: f(T)

Amount Units:

Velocity Units:

Ejemplo: Reactor CSTR y PFR



$$k_1 = \exp(13.62 - 8220/T)$$

$$k_1 = e^{13.62} e^{-8220/T} \left[\frac{L}{mol \cdot min} \right]$$

$$k_1 = \frac{e^{13.62}}{60 \times 1000} e^{-\frac{E_1}{RT}} \left[\frac{m^3}{mol \cdot s} \right]$$

A_1

$$A_1 = \frac{e^{13.62}}{60 \times 1000} \left[\frac{m^3}{mol \cdot s} \right]$$

$$-\frac{E_1}{RT} = -\frac{8220}{T}$$

$$E_1 = 8220R$$

$$E_1 = 8220[K] \times 8.314472 \left[\frac{J}{mol \cdot K} \right]$$

$$A_1 = 13.7069 \left[\frac{m^3}{mol \cdot s} \right]$$

$$E_1 = 68344.9598 \left[\frac{J}{mol} \right]$$

Ejemplo: Reactor CSTR y PFR

Chemical Reactions

+ - + -

Name
R1
R2
R3

Edit Kinetic Reaction

Identification

Name: R1

Descriptio

Components, Stoichiometry and Reaction Orders

Name	Molar Weight	ΔH_f (kJ/kg)	Include	BC	Stoich. Coeff.	DO	RO
Ethylene oxide	44.0526	-1194.7081	<input checked="" type="checkbox"/>	<input checked="" type="checkbox"/>	-1	1	0
Water	18.015	-13422.925	<input checked="" type="checkbox"/>	<input type="checkbox"/>	-1	1	0
Ethylene glycol	62.0678	-6318.8964	<input checked="" type="checkbox"/>	<input type="checkbox"/>	1	0	0
Diethylene glycol	106.12	-5148.8881	<input type="checkbox"/>	<input type="checkbox"/>	0	0	0
Triethylene glycol	150.173	-4828.4312	<input type="checkbox"/>	<input type="checkbox"/>	0	0	0

Stoichiometry: Heat of Reaction (kJ/kmol_BC): -97756

Equation: CH2OCH2 + HOH <=> HOCH2CH2OH

Kinetic Reaction Parameters

Base Component: Ethylene oxide

Basis: Molar Concentrations

Phase: Liquid

Tmin (K): 0

Tmax (K): 3500

Direct and Reverse Reactions Velocity Constant (k and k')

Direct Reaction: Arrhenius A: 13.706911 E: 68344.9598 E in J/mol, T in K

User-Defined: f(T)

Reverse Reaction: Arrhenius A': 0 E': 0 E in J/mol, T in K

User-Defined: f(T)

Amount Units: mol/m³ Velocity Units: mol/[m³.s]

Ejemplo: Reactor CSTR y PFR

Chemical Reactions

Name
R1
R2
R3

Edit Kinetic Reaction [X]

Identification

Name:

Descriptio:

Components, Stoichiometry and Reaction Orders

Name	Molar Weight	ΔHf (kJ/kg)	Include	BC	Stoich. Coeff.	DO	RO
Ethylene oxide	44.0526	-1194.7081	<input checked="" type="checkbox"/>	<input type="checkbox"/>	-1	1	0
Water	18.015	-13422.925	<input type="checkbox"/>	<input type="checkbox"/>	0	0	0
Ethylene glycol	62.0678	-6318.8964	<input checked="" type="checkbox"/>	<input checked="" type="checkbox"/>	-1	1	0
Diethylene glycol	106.12	-5148.8881	<input checked="" type="checkbox"/>	<input type="checkbox"/>	1	0	0
Triethylene glycol	150.173	-4828.4312	<input type="checkbox"/>	<input type="checkbox"/>	0	0	0

Stoichiometry: Heat of Reaction (kJ/kmol_BC):

Equation:

Kinetic Reaction Parameters

Base Component:

Basis: Tmin (K):

Phase: Tmax (K):

Direct and Reverse Reactions Velocity Constant (k and k')

Direct Reaction: Arrhenius A: E: E in J/mol, T in K

User-Defined: f(T)







Reverse Reaction: Arrhenius A': E': E in J/mol, T in K

User-Defined: f(T)

Amount Units: Velocity Units:

Ejemplo: Reactor CSTR y PFR

Chemical Reactions

-      
- Name
- R1
- R2
- R3

Edit Kinetic Reaction ✕

Identification

Name

Descriptio

Components, Stoichiometry and Reaction Orders

Name	Molar Weight	ΔH_f (kJ/kg)	Include	BC	Stoich. Coeff.	DO	RO
Ethylene oxide	44.0526	-1194.7081	<input checked="" type="checkbox"/>	<input type="checkbox"/>	-1	1	0
Water	18.015	-13422.925	<input type="checkbox"/>	<input type="checkbox"/>	0	0	0
Ethylene glycol	62.0678	-6318.8964	<input type="checkbox"/>	<input type="checkbox"/>	0	0	0
Diethylene glycol	106.12	-5148.8881	<input checked="" type="checkbox"/>	<input checked="" type="checkbox"/>	-1	1	0
Triethylene glycol	150.173	-4828.4312	<input checked="" type="checkbox"/>	<input type="checkbox"/>	1	0	0

Stoichiometry Heat of Reaction (kJ/kmol_BC)

Equation

Kinetic Reaction Parameters

Base Component

Basis Tmin (K)

Phase Tmax (K)

Direct and Reverse Reactions Velocity Constant (k and k')

Direct Reaction Arrhenius A E E in J/mol, T in K

User-Defined: f(T)

Reverse Reaction Arrhenius A' E' E in J/mol, T in K

User-Defined: f(T)

Amount Units Velocity Units

Ejemplo: Reactor CSTR y PFR

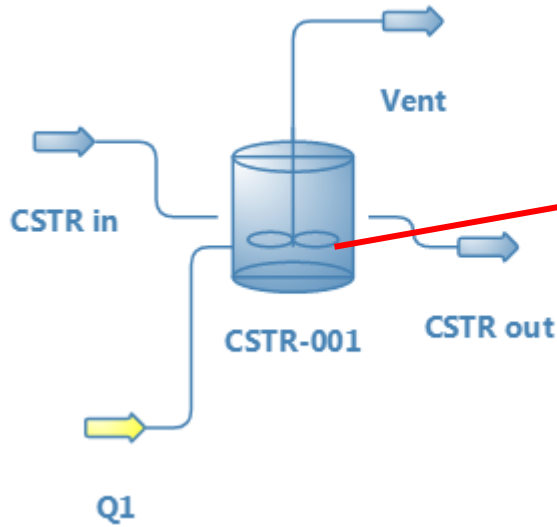

Calculation Parameters

Reaction Set	Default Set	
Calculation Mode	Isothermic	
Outlet Temperature	25	C
Reactor Volume	4	m ³
Headspace	0	m ³
Reactor Pressure Drop	0	kgf/cm ²
Catalyst Amount	0	kg

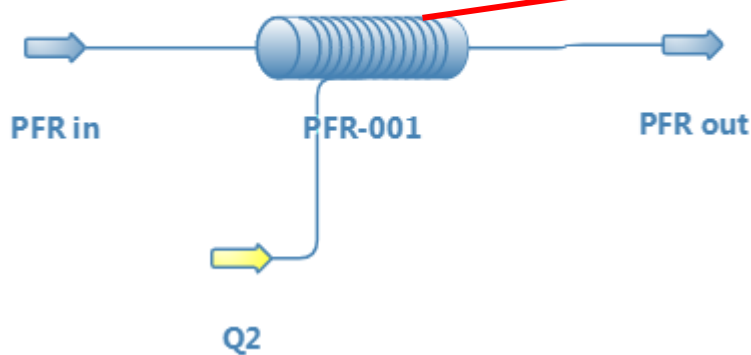

Calculation Parameters

Reaction Set	Default Set	
Calculation Mode	Isothermic	
Outlet Temperature	25	C
Reactor Volume	4	m ³
Reactor Length	10	m
Catalyst Loading	0	kg/m ³
Catalyst Particle Diameter	0	mm
Catalyst Void Fraction	0	

Ejemplo: Reactor CSTR y PFR

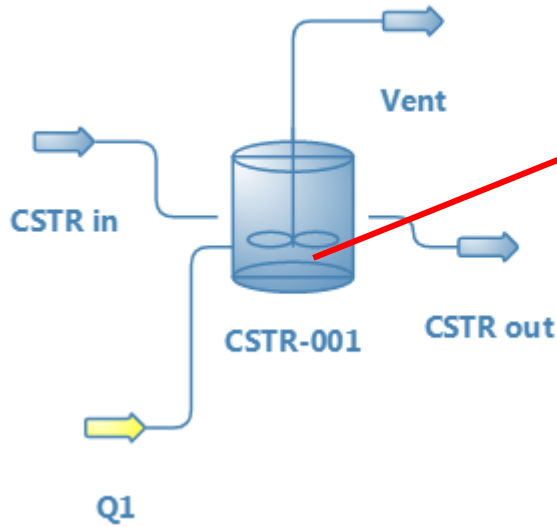

Results

Compound	Conversion (%)
Water	4.37499
Ethylene oxide	11.0937
Ethylene glycol	0
Diethylene glycol	0
Triethylene glycol	0

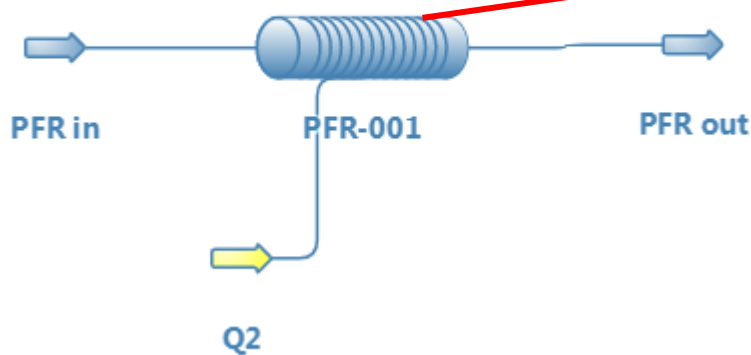

Results

Compound	Conversion (%)
Water	4.72378
Ethylene oxide	11.5431

Análisis Paramétrico

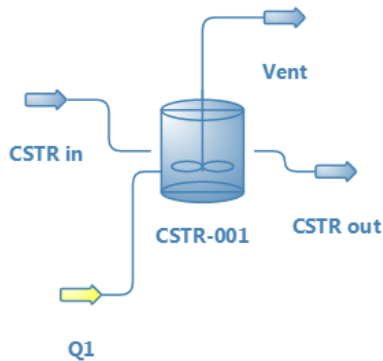

Se analizará de manera automática la variación de la composición de salida con el tamaño del reactor

Practico IV\2018\Practicos\R1 R2 y R3.dwg

Optimization

Scripts

Results



Sensitivity Analysis



Multivariate Optimizer

Flowsheet Material Streams Spreadsheet Sensitivity Analysis ×

Sensitivity Studies Independent Variables Dependent Variables Results Chart

Case Manager

New Copy Save Delete

Reactor

Name and Description

Name Reactor

Description

Análisis Paramétrico

The image shows a software interface for parametric analysis. The 'Independent Variables' tab is selected, and the settings for 'Independent Variable 1' are displayed. The 'Object' is 'CSTR-004' and the 'Property' is 'Volume'. The 'Lower Limit' is 4, 'Upper Limit' is 50, and 'Number of Points' is 30. The 'Current Value' is 4. The unit is 'm3'.

Parameter	Value
Object	CSTR-004
Property	Volume
Lower Limit	4
Upper Limit	50
Number of Points	30
Current Value	4
Unit	m3

Análisis Paramétrico

Sensitivity Studies | Independent Variables | Dependent Variables | Results | Chart

Variables Expression

Add/Remove Variables

	Object	Property	Unit
+			
-			

Expression Parameters

	Name	Object	Property	Value	Unit
+					
-					

Add/Remove Variables

	Object	Property	Unit
+			
-			
1	CSTR out	Molar Fraction (Mixture) / Ethylene gly...	
2	CSTR out	Molar Fraction (Mixture) / Diethylene gl...	
3	CSTR out	Molar Fraction (Mixture) / Triethylene glyc	

Expression

Expression

Verify

Clear

Curr. Value

Análisis Paramétrico

Sensitivity Studies | Independent Variables | Dependent Variables | Results | Chart

Start Sensitivity Analysis | Break Calculation

Results

IV 1

Sensitivity Studies | Independent Variables | Dependent Variables

Start Sensitivity Analysis | Break Calculation

Results

CSTR-004 - Volume (m3)	CSTR out -	CSTR out - Molar Fraction (Mixture) / Triethylene glycol ()
21.4483	0.0875446	0.0068089
23.0345	0.0903618	0.00755617
24.6207	0.0931790	0.00830334
26.2069	0.0960000	0.00905051
27.7931	0.0988250	0.00979768
29.3793	0.1016560	0.01054485
30.9655	0.1044910	0.01129202
32.5517	0.1073310	0.01203919
34.1379	0.1101760	0.01278636
35.7241	0.1130270	0.01353353
37.3103	0.1158830	0.01428070
38.8965	0.1187440	0.01502787
40.4827	0.1216100	0.01577504
42.0689	0.1244810	0.01652221
43.6551	0.1273570	0.01726938
45.2413	0.1302380	0.01801655
46.8276	0.1331250	0.01876372
48.4138	0.1360170	0.01951089
50	0.1389140	0.02025806

Information

Run #27 completed...
Run #28 completed...
Run #29 completed...
Run #30 completed...
Restoring simulation to its original state...
Done!

Análisis Paramétrico

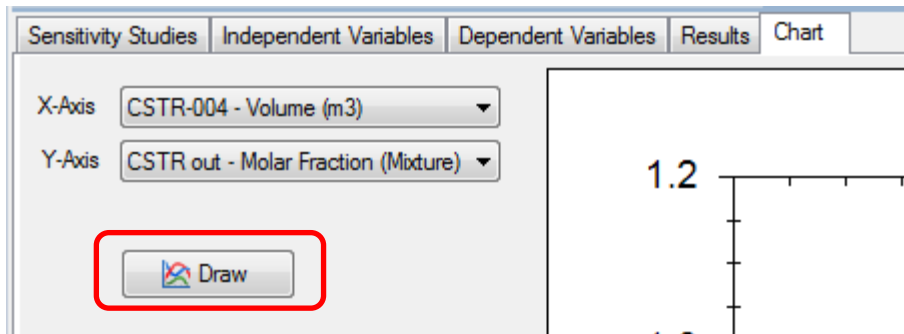

CSTR-004 - Volume (m3)	CSTR out - Molar Fraction (Mixture) / Ethylene glycol ()	CSTR out - Molar Fraction (Mixture) / Diethylene glycol ()	CSTR out - Molar Fraction (Mixture) / Triethylene glycol ()
21.4483	0.0875446	0.0218151	0.0098089
23.0345	0.0903618	0.0232322	0.00759617
24.6207	0.092965	0.0245766	0.00829697
26.2069	0.0953788	0.0258547	0.00902711
27.7931	0.0976181	0.0270669	0.00974543
29.3793	0.0997051	0.02822	0.0104492

Copiamos los datos y los pegamos en Excel

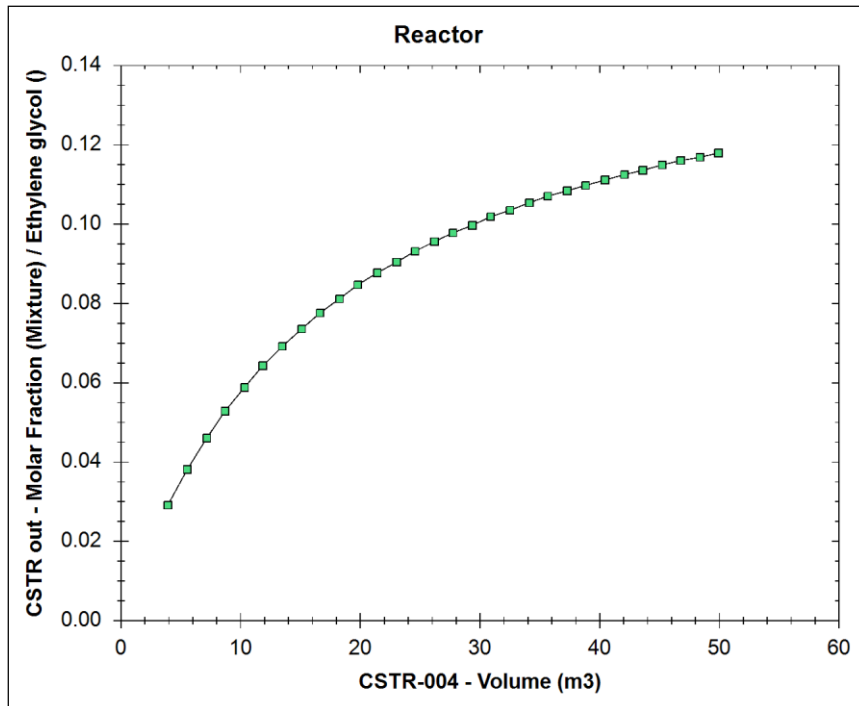

Análisis Paramétrico

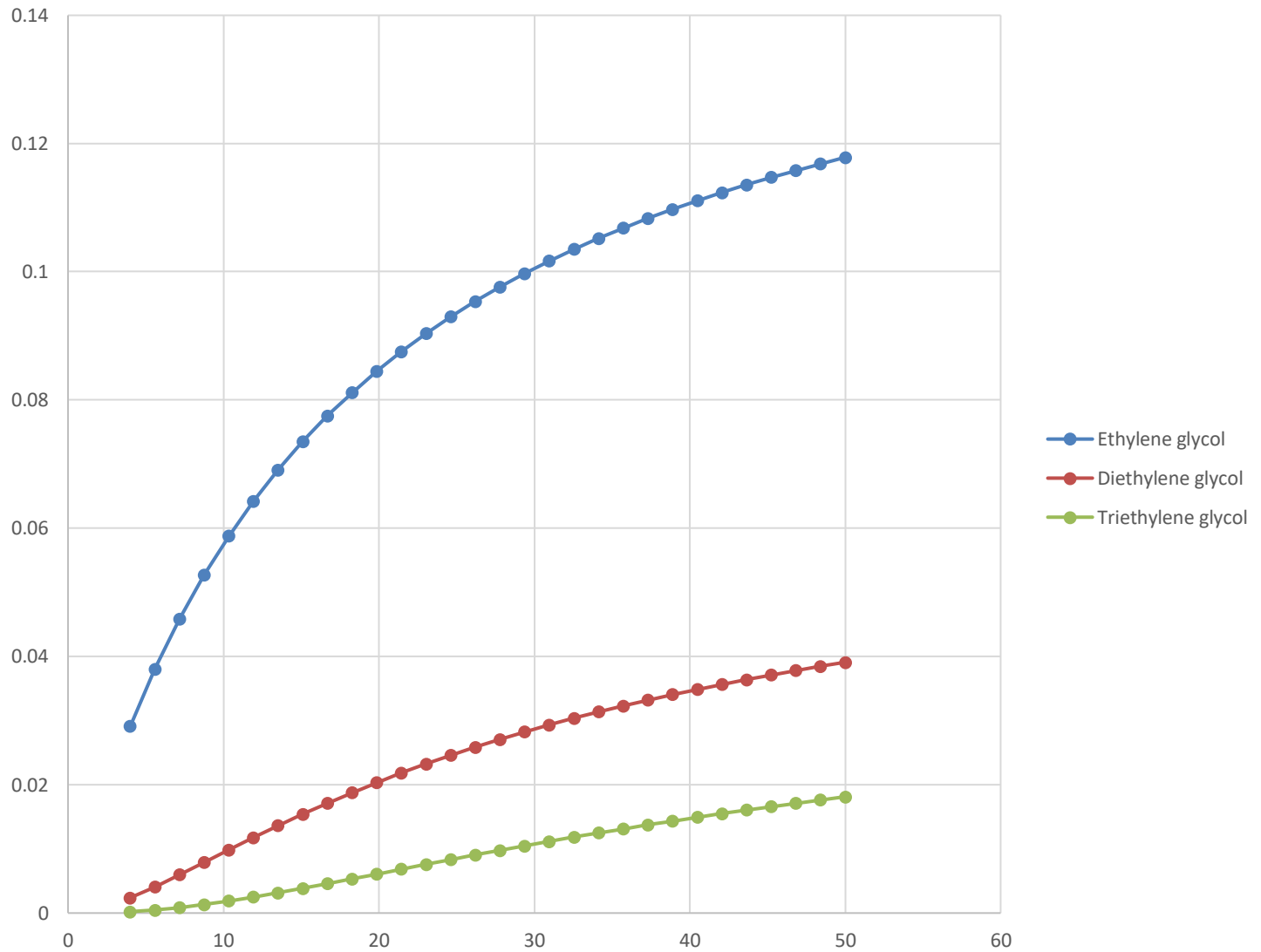

Análisis Paramétrico

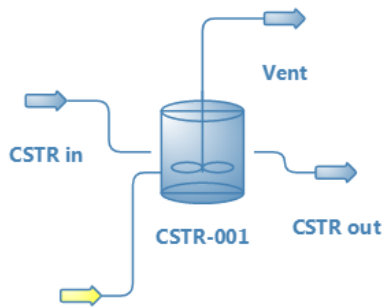

Se analizará la variación de la conversión del EtO con el tamaño del reactor

O1
Sensitivity Studies

Independent Variables | Dependent Variables | Results | Chart

Case Manager

New | Copy | Save | Delete

Reactor
Conversión

Name and Description

Name: Conversión

Description:

Independent Variable 1

Object: CSTR-004 | Property: Volume

Lower Limit: 4 | Number of Points: 40 | Unit: m3

Upper Limit: 150 | Current Value: 4

Análisis Paramétrico

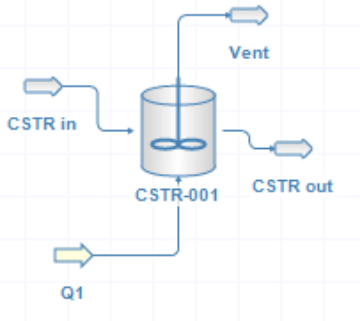

Se analizará la variación de la conversión del EtO con el tamaño del reactor

The screenshot shows a software interface for sensitivity studies. The 'Variables' tab is active. A table lists properties for 'CSTR-004'. A dropdown menu is open, showing a list of properties: Heat load, Outlet Temperature, Pressure Drop, Residence time, Temperature delta, and Volume. The 'Expression' radio button is selected. The 'Expression Parameters' table is empty.

Object	Property	Unit
1	CSTR-004	

- Heat load
- Outlet Temperature
- Pressure Drop
- Residence time
- Temperature delta
- Volume

Name	Obj
------	-----

¿Conversión?

$$x_{EtO} =$$

Análisis Paramétrico

Molar Flow (Mixture) / Ethylene Oxide

Expression

Expression Parameters

	Name	Object	Property	Value	Unit
1	F_in	CSTR in	Molar Flow (Mixture) / Ethylen...	30	mol/s
2	F_out	CSTR out	Molar Flow (Mixture) / Ethylen...	26.6719	mol/s

Variables del flowsheets que necesito para la expresión de la conversión

$$x_{EtO} = \frac{F_{EtO_{in}} - F_{EtO_{out}}}{F_{EtO_{in}}}$$

Moles consumidos de EtO
Moles alimentados de EtO

Análisis Paramétrico

Expression

Expression Parameters

	Name	Object	Property
1	F_in	CSTR in	Molar Flow (Mixture) / Ethylen...
2	F_out	CSTR out	Molar Flow (Mixture) / Ethylen...

Results

General Reactions Conversions

Compound	Conversion (%)
Water	4.37499
Ethylene oxide	11.0937
Ethylene glycol	0
Diethylene glycol	0
Triethylene glycol	0

Expression

Expression (F_in-F_out)/F_in

Hand icon pointing to the expression field

Verify

Clear

Curr. Value 0.110936666666667

$$x_{EtO} = \frac{F_{EtO_{in}} - F_{EtO_{out}}}{F_{EtO_{in}}}$$

Moles consumidos de EtO
Moles alimentados de EtO

Análisis Paramétrico

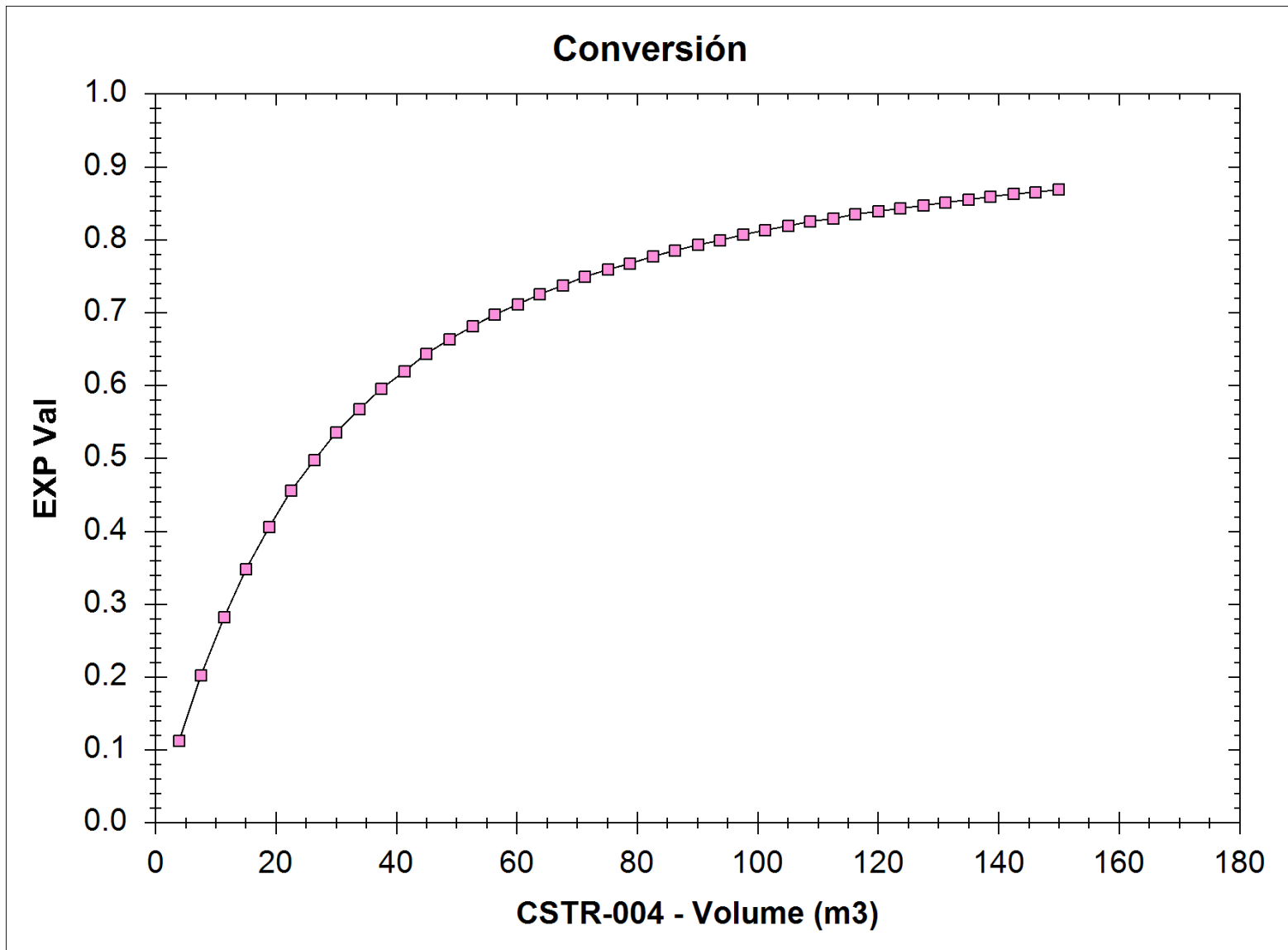

Estudio paramétrico del reactor de equilibrio

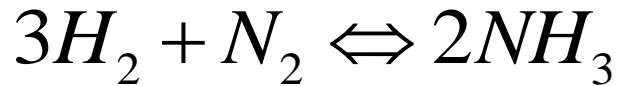

Edit Equilibrium Reaction

Identification
Name: Ammonia Gibbs
Description:

Components/Stoichiometry

Name	Molar Weight	Include	BC	Stoich. Coeff.
Ammonia	17.031	<input checked="" type="checkbox"/>	<input type="checkbox"/>	2
Nitrogen	28.014	<input checked="" type="checkbox"/>	<input checked="" type="checkbox"/>	-1
Hydrogen	2.01588	<input checked="" type="checkbox"/>	<input type="checkbox"/>	-3

Stoichiometry: OK Balance Heat of Reaction (kJ/kmol_BC) (25°C): -91796

Equation: N2 + 3H2 <-> 2NH3

Equilibrium Reaction Parameters
Basis: Fugacity Phase: Vapor Tmin (K): 0 Tmax (K): 0
Approach (%): 0

Equilibrium Constant (Keq)
 Calculate from Gibbs Energy of Reaction DelG_R (kJ/kmol_BC) (25°C): -32800
 T-Function.: ln Keq [f(T)] = T in K
 Constant Value: 0

Use '.' as the decimal separator on math expressions.

Cancel OK

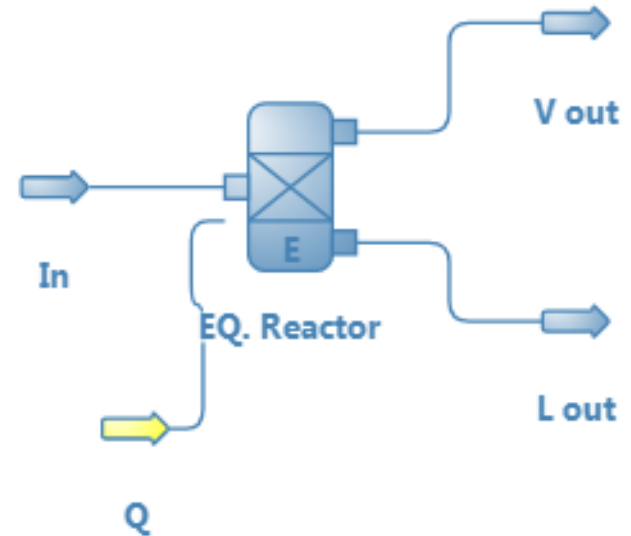

Estudio paramétrico del reactor de equilibrio

Independent Variable 1

Object Property

Lower Limit Number of Points Unit

Upper Limit Current Value

Independent Variable 2

Object Property

Lower Limit Number of Points Unit

Upper Limit Current Value

Expression

Expression Parameters

	Name	Object	Property	Value	Unit
	F_in	<input type="text" value="In"/>	<input type="text" value="Molar Flow (Mixture) / Nitro..."/>	2.5	mol/s
▶ 2	F_out	<input type="text" value="V out"/>	<input type="text" value="Molar Flow (Mixture) / Nitro..."/>	1.2295156	mol/s

Expression

Expression

Verify

Clear

Curr. Value

Estudio paramétrico del reactor de equilibrio

Start Sensivity Analysis Break Calculation Send Data to Regression Plugin

Results

In - Pressure (bar)	In - Temperature (C)	EXP Val
100	350	0.55717001
100	372.22222	0.49019011
100	394.44444	0.42547633
100	416.66667	0.36498595
100	438.88889	0.31011832
100	461.11111	0.26162601
100	483.33333	0.2196862
100	505.55556	0.18403593
100	527.77778	0.15407368
100	550	0.1291494
350	350	0.79041341
350	372.22222	0.74217784
350	394.44444	0.69053163
350	416.66667	0.63659645
350	438.88889	0.58162073
350	461.11111	0.52686951
350	483.33333	0.47355588
350	505.55556	0.42267531
350	527.77778	0.37506876
350	550	0.33137416
600	350	0.86866053
600	372.22222	0.83209053
600	394.44444	0.79125309

Information

Run #27 completed...
Run #28 completed...
Run #29 completed...
Run #30 completed...
Restoring simulation to its original state...
Done!

Estudio paramétrico del reactor de equilibrio

